

# Extending Design by Contract for Aspect-Oriented Programming

David H. Lorenz   Therapon Skotiniotis  
 Technical Report NU-CCIS-04-14  
 College of Computer & Information Science  
 Northeastern University  
 Boston, Massachusetts 02115 USA  
 { lorenz, skotthe }@ccs.neu.edu

## ABSTRACT

Design by Contract (DbC) and runtime enforcement of program assertions enables the construction of more robust software. It also enables the assignment of blame in error reporting. Unfortunately, there is no support for runtime contract enforcement and blame assignment for Aspect-Oriented Programming (AOP). Extending DbC to also cover aspects brings forward a plethora of issues related to the correct order of assertion validation. We show that there is no generally correct execution sequence of object assertions and aspect assertions. A further classification of aspects as *agnostic*, *obedient*, or *rebellious* defines the order of assertion validation that needs to be followed. We describe the application of this classification in a prototyped DbC tool for AOP named CONA, where aspects are used for implementing contracts, and contracts are used for enforcing assertions on aspects.

## 1. INTRODUCTION

*Design by Contract* (DbC) [22] is a methodology for software construction that is based on runtime enforcement of assertions. Several object-oriented programming (OOP) languages follow the Eiffel [23] example in providing support for DbC (including, e.g., Blue [14] and Sather [24]). Unfortunately, no aspect-oriented programming (AOP) language offers support for DbC. This paper extends DbC for controlling also the interactions between advice and methods [25], a need that is evident in any non-trivial AOP application development [11].

While runtime contract enforcement and blame assignment for objects is well understood, it is unclear how DbC extends to aspects. In DbC for OOP, assertions are enforced during method invocation; a failure clearly implicates one of two distinct objects, the caller or the callee. In DbC for AOP, there are two kinds of entities (objects and aspects), two different kinds of assertions (assertions for objects and assertions for aspects), and no implicit caller (for an aspect's advice).

DbC for OOP also validates logical implications between super-type assertions and subtypes assertions on methods [9]: an overriding method must be a behavioral substitute [18] for its overridden counterpart. In comparison, DbC for AOP must validate that the method with an advice is a behavioral substitute for its advice-less counterpart.

These differences brings about several issues:

- (i) At what point during the execution of the program should each kind of assertion be checked?
- (ii) Should there be a connection between assertions on methods and assertions on advice and how should that be enforced at runtime?
- (iii) How is blame assignment affected?

In this paper we extend the classic DbC runtime contract enforcement mechanism to cover AspectJ's [20, 12, 3] advice definitions. We concentrate on the impact of the relative interleaving order of object contract checking and aspect contract checking.

In Section 2, we show that there is no generally applicable correct order. In Section 3, we develop a classification of aspects according to the way they influence object contracts. We classify each aspect as either *agnostic*, *obedient*, or *rebellious*, and show that the membership of an aspect in one of the defined categories implies a particular order. Based on this classification, the execution order of method invocation (and its advice and assertions) changes, in order to properly assign blame for any contract violations that may occur.

Enforcing contracts via aspects is also an application area of aspects that serves as an illustration for the need to differentiate between *agnostic*, *obedient*, and *rebellious* aspects. In Section 4, we present CONA [21, 29, 28, 26], a tool for the provision and enforcement of DbC in both OOP and AOP.

## 2. MOTIVATING EXAMPLE

Consider a software system for an online bookstore (Figure 1) with offices in the USA, Greece, and Israel. A book sale transaction requires a non-empty ISBN number (pre-condition of `OnlineBookstore.sale`). The sale completes by providing a book that either matches the requested ISBN number or has the same title (post-condition of `OnlineBookstore.sale`) but possibly a different ISBN. The post-condition in `OnlineBookstore.sale` permits to substitute

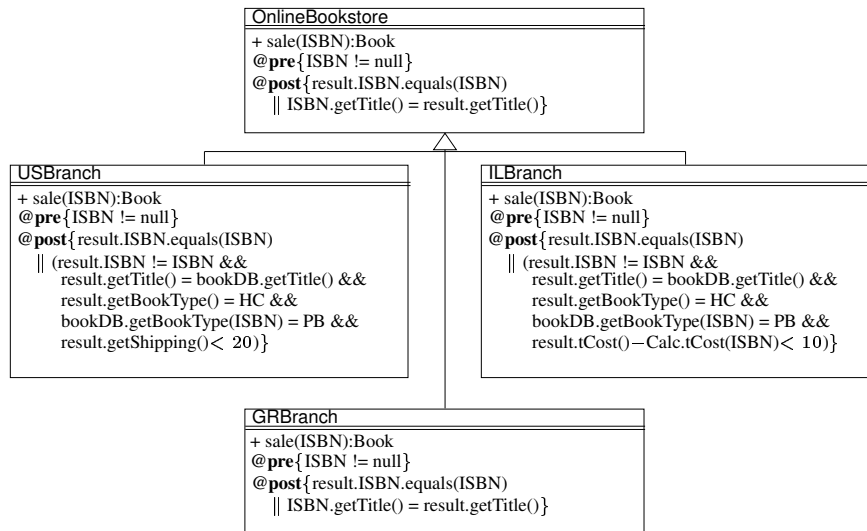

Figure 1: The online bookstore has offices in USA, Greece, and Israel. Each site has different taxes (Sales, VAT) and also different shipping agencies. `sale` is overwritten, however, the contracts associated with each method implementation make the three subclasses proper behavioral subtypes of `OnlineBookstore`.

the requested book with a different edition of the book<sup>1</sup> (e.g., a paperback (PB) version instead of a hardcover (HC) version, or vice versa).

Concrete subclasses of `OnlineBookstore` specialize `sale` to reflect the policy in effect in each of the three different countries. Specifically,

- In the USA, an order for a paperback version of a book that is not available in the bookstore may be fulfilled with a hardcover version of the book as long as the shipping costs for the hardcover version does not exceed the amount of 20 Dollars.
- In Greece, an order for a book that is not in-stock but another version (paperback or hardcover) is available is fulfilled by providing that version instead.
- In Israel, if the requested book is a paperback but the bookstore has only the hardcover version, then the hardcover is provided as long as the difference in the total cost (book price *plus* shipping) is less than 10 Shekels.

The post-condition on the specialized implementations of `sale` capture the corresponding country’s policy, which needs to be checked at runtime.

In terms of contracts (transactions) the role of provider (server) is played by the online bookstore software. The consumer (client) role is played by the customer that uses the online bookstore software.

## 2.1 Contracts in the Presence of Aspects

Interesting issues arise in the situations where user aspects are present in the system where contracts (regardless of how they are being

<sup>1</sup>We assume that two books with the same title are either the same or different editions of the same book. That is, there do not exist two books of different contents with the same title in the bookstore.

implemented) are used. Since an aspect may observe or alter information before, after, or around a method’s call/execution, a user aspect’s advice might:

- Break a method’s pre-condition even when the client calls the method correctly.
- Break a method’s post-condition even when the method’s pre- and post-condition where fulfilled by the method’s implementation.
- Correct a call to a method *m* that originally violated *m*’s pre-condition.
- Correct a previously erroneous implementation that did not fulfill its post-condition.
- Add extra behavior to a method’s implementation without altering the set of states accepted by the pre- and post-condition assertions, i.e., provide a different mapping for the same input and output value sets of the method.
- Add extra behavior by extending the method’s specification (pre- and/or post-conditions).
- Monitor a method’s execution by collecting information or checking certain system properties without affecting the behavior of the method.

The order of execution amongst aspect advice, pre- and post-condition validation, and method execution determines which one of the above situations occur. For example, behavioral extension via aspect advice should only be allowed when aspect advice is executed before a method’s pre-condition or post-condition validation.

Consider (the addition of an aspect that will implement) an increase of 10% in shipping cost on hardcover books (Listing 1). `ShippingCost` is added to the system and attached to `sale` method calls with an after advice holding the relevant code for the enforcement of the extra cost. Focusing on `sale` method calls, it is not

Listing 1: ShippingCost aspect adding the 10% extra shipping cost on hardcover editions.

```

1 aspect ShippingCost{
2   pointcut HDSales(ISBN isbn): call(* OnlineBookstore.sales(..)
3     ) && args(isbn);
4
5   after(ISBN isbn) returning (Book item):
6     HDSales(isbn){
7       item.setShippingCost(item.getShippingCost() * 1.1);
8       item.calculateTotalCost();
9     }
}

```

obvious what execution sequence amongst pre- and post-condition validation, aspect advice and method execution should be followed. Three possibilities (Table 1) are possible and we will examine each one in turn within the context of the on line bookstore example.

Assuming an execution policy where user aspects are executed before pre-conditions and after post-condition are enforced (execution order A in Table 1), clients to both the USBranch and ILBranch may be charged more than what was agreed. Although the client has maintained the originally agreed upon contract, the final outcome breaks the clients expectations blaming the provider.

The shipping cost increase introduced via the aspect can result to shipments where the total shipping cost will be more than \$20 and a total cost that is more than 10 Shekels. From the clients point of view, it is clearly an error of the online bookstore since the agreed policy for replacing a paperback edition was not followed.<sup>2</sup> At the same time the corresponding branches have assurances (sale's post-condition) that the replacement policy was honored. DbC mechanisms fail to correctly assign blame in the presence of aspects, misguiding developers and increasing the time spend on bug detection and correction. It is clear that the party that is actually at fault here is the aspect. One can conclude that the aspect is at fault only after observing all three entities, their execution sequence and their interactions.

However, an aspect can also be used to bring about the exact opposite effect. An aspect can intervene after the return of a method that originally returned a faulty result which violated the post-condition and modify the result in such a way so that now the post-condition is not violated. The execution interleaving would have to allow such aspects to intervene before the runtime check for a methods post-condition (execution order B in Table 1). These situations are examples of extensions/fixes through aspects.

In the case of the online bookstore, suppose that a 20% markdown is in effect for all hardcover editions. Consider a customer in Israel ordering a book using the ISBN of the paperback edition. Suppose the paperback edition costs 80 Shekels and the hardcover edition costs 100 Shekels. The bookstore does not have any copies of the paperback edition and provides the hardcover edition of the book instead. Before applying the 20% markdown on the hardcover edition, the post-condition of the ILBranch disallows the switch from paperback to hardcover since the difference in cost is more than 10 Shekels. However if the aspect is allowed to intervene before the

<sup>2</sup>In fact an OOP runtime contract enforcement mechanism will blame the corresponding bookstore branch since it does not take into account aspects and their specification.

post-condition check is enforced then the difference in total cost is 0 Shekels and the sale can go through.

One may resort to a conservative approach in which a method's pre-condition is checked twice: once before the advice and once before the method (execution order C in Table 1). However, that would restrict the applicable aspects, thereby compromising obliviousness [8].

### 3. A CLASSIFICATION OF ASPECTS FOR DBC

Aspects can be used:

- (i) to enforce properties without altering the behavior of the underlying system (e.g., logging the online bookstore system, checking the online bookstore coding style [17], implementing the DbC assertions found in Figure 1 [cf. Section 4].
- (ii) to allow for extensions to the behavior of the underlying system, (e.g., allowing for extra charges/discounts on the online bookstore).

The two different uses of aspects in the presence of contracts imposes certain restrictions on their execution order. Furthermore, it may result in erroneous blame assignments complicating error detection and resolution.

The choice of which interleaving execution order (Table 1) to enforce also depends on the mechanism of assigning blame in cases of violation. Standard DbC mechanisms are ignorant of aspects. Blame assignment must therefore be extended to deal with aspects as entities that can be assigned blame. Also, what is being violated has to be redefined in order to take into account the intention of code found in aspect definitions.

The ability to define an aspect's intentions through a clear declarative specification as well as the runtime validation of these intentions is crucial in error detection, error resolution and reasoning about aspect-oriented programs. We identify three intentional categories of aspects: namely, *agnostic*, *obedient*, and *rebellious*.

#### 3.1 Agnostic Aspects

*Agnostic* aspects are aspects that do not affect a method's assertions in any way. Agnostic aspects are "sandwiched" with the original method's pre- and post-conditions. From the perspective of the callers of the method, the method with the advice (as on body) has the same assertions as the original method body. In addition, assertions do not change from the method's perspective either.

##### 3.1.1 Execution Order

The language imposes the following execution sequence in the case of agnostic aspects (execution order C):

$$m_{pre} \rightsquigarrow \alpha_{pre}^{bef} \rightsquigarrow \alpha \rightsquigarrow \alpha_{post}^{bef} \rightsquigarrow m_{pre} \rightsquigarrow m \rightsquigarrow m_{post} \rightsquigarrow \alpha_{pre}^{after} \rightsquigarrow \alpha \rightsquigarrow \alpha_{post}^{after} \rightsquigarrow m_{post}$$

Where

- $\alpha_{pre}^{bef}$  denotes to the pre-condition of the aspect's ( $\alpha$ ) before advice

Policy	Execution Interleaving												
Exec Order A	$\alpha$	$\rightsquigarrow$	$m_{pre}$	$\rightsquigarrow$	$m$	$\rightsquigarrow$	$m_{post}$	$\rightsquigarrow$	$\alpha$				
Exec Order B	$m_{pre}$	$\rightsquigarrow$	$\alpha$	$\rightsquigarrow$	$m$	$\rightsquigarrow$	$\alpha$	$\rightsquigarrow$	$m_{post}$				
Exec Order C	$m_{pre}$	$\rightsquigarrow$	$\alpha$	$\rightsquigarrow$	$m_{pre}$	$\rightsquigarrow$	$m$	$\rightsquigarrow$	$m_{post}$	$\rightsquigarrow$	$\alpha$	$\rightsquigarrow$	$m_{post}$

Table 1: Three alternative policies of interleaving execution (form left to right) of contracts checking pre- and post-conditions ( $m_{pre}$  and  $m_{post}$  respectively) with advice from an aspect ( $\alpha$ ).

- $\alpha_{post}^{bef}$  denotes to the post-condition of the aspect's ( $\alpha$ ) before advice
- $m_{pre}$  denotes to the method's ( $m$ ) pre-condition
- $m_{post}$  denotes to the method's ( $m$ ) post-condition
- $\alpha_{pre}^{after}$  denotes to the pre-condition of the aspect's ( $\alpha$ ) after advice
- $\alpha_{post}^{after}$  denotes to the post-condition of the aspect's ( $\alpha$ ) after advice

This execution sequence makes sure that the original method's pre- and post-condition is validated both before advice execution and after advice execution.

### 3.1.2 Blame Assignment

Runtime assertion validation and blame assignment for agnostic aspects is described in Table 2. On top of checking for each individual assertion at runtime extra implications between assertions are validated to guarantee proper execution flow between aspect advice and method implementation. The method's pre-condition has to imply the before advice pre-condition making sure that the aspect developer took into account the valid start states of the method. Furthermore, before advice post-condition has to imply the methods pre-condition. Since no alteration of behavior is allowed in agnostic aspects execution of the method's implementation must start in a valid state satisfying the methods pre-condition.

Similarly, the method's post-condition must imply the after advice pre-condition. This is again the responsibility of the aspect developer who is required to begin any agnostic aspect after advice from a valid state according to the method's post-condition. Finally, after advice post-condition must directly imply the method's post-condition. Upon completion of an agnostic aspect's after advice there should be no change in the method's behavior and specification. Furthermore, the return values of the after advice are the return values of the method call as a whole and thus the method's post-condition must also hold.

Assertion Validation	Blame Assignment
$m_{pre}$	Caller
$m_{pre} \rightarrow \alpha_{pre}^{bef}$	Aspect
$\alpha_{post}^{bef}$	Advice
$\alpha_{post}^{bef} \rightarrow m_{pre}$	Aspect
$m_{pre}$	Advice
$m_{post}$	Method
$m_{post} \rightarrow \alpha_{pre}^{after}$	Advice
$\alpha_{pre}^{after}$	Advice
$\alpha_{post}^{after}$	Advice
$\alpha_{post}^{after} \rightarrow m_{post}$	Aspect
$m_{post}$	Aspect

Table 2: Implications for agnostic aspect assertions and blame assignment. Order of execution goes from top (first) to bottom (last).

## 3.2 Obedient Aspects

Another form of extension to the base system is one where the set of input and output states remains the same but the mapping of input to output values changes. In these situations the aspect with such an intended extension is categorized as an obedient aspect.

*Obedient* aspects are aspects used to provide extra behavior without changing the method's pre- and post- conditions, i.e., obedient aspects just provide a different mapping from the same input to the same output value sets of the method. From the perspective of a caller of the method, the method with the advice has the same assertions as the original method had.

### 3.2.1 Execution Order

Declaring an obedient aspect imposes the following execution sequence (execution order B):

$$m_{pre} \rightsquigarrow \alpha_{pre}^{bef} \rightsquigarrow \alpha \rightsquigarrow \alpha_{post}^{bef} \rightsquigarrow m \rightsquigarrow \alpha_{pre}^{after} \rightsquigarrow \alpha \rightsquigarrow \alpha_{post}^{after} \rightsquigarrow m_{post}$$

Adding an obedient aspect does not alter the pre- and post-conditions of the method as they are known to the rest of the system. The first assertion validation is still the original method's pre-condition and the last assertion validation is the original method's post-condition.

### 3.2.2 Blame Assignment

Once the method's pre-condition has been successful validated this should immediately imply the pre-condition for the aspect's before advice is also true. The aspect developer knows the method's pre-condition and has defined the aspect to be an obedient aspect, it is therefore the aspect developer's responsibility to accept all legal starting states of the method as legal starting states of the aspect's before advice. Failing to do so will signal an error blaming the aspect developer for attempting to use an obedient aspect without taking into account the original method's pre-condition (Table 3).

The aspect's before advice post-condition is then checked. Failing the before advice post-condition blames the advice code for not fulfilling the expected assertion upon its termination. The next assertion to be checked is an implication relation between the original method's post-condition and the after advice pre-condition. Blame is assigned to the aspect developer in the case of failure, for declaring an obedient aspect and not taking into account the method's post-condition as a valid start state for the aspect's after

Assertion Validation	Blame Assignment
$m_{pre}$	Caller
$m_{pre} \rightarrow \alpha_{pre}^{bef}$	Aspect
$\alpha_{post}^{bef}$	Advice
$m_{post} \rightarrow \alpha_{pre}^{after}$	Aspect
$\alpha_{pre}^{after}$	Advice
$\alpha_{post}^{after}$	Advice
$\alpha_{post}^{after} \rightarrow m_{post}$	Aspect

Table 3: Assertions validated for obedient aspects (execution flows from top to bottom) along with blame assignments.

advice. The after advice pre-condition is then checked, blaming the composition rules (pointcuts) in the case of an error. The after advice post-condition validation follows which blames the advice code in case of an error. Finally an implication between the after advice post-condition and the original method's post-condition is validated. This check makes sure that the state in which the after advice terminates (and thus the whole call to the method) does so in valid state according to the method's original post-condition.

The difference between agnostic and obedient aspects is subtle. In both cases, if the method pre-condition is valid, we can invoke the method with its advice, and the result satisfies the post-condition. However, in the case of the obedient aspect it is possible that a before aspect will invalidate the precondition, the method is executed on a state that does not satisfy the precondition, and an after advice fixes the postcondition (if necessary). With agnostic aspects, the method code executes only in the context it was meant for.

### 3.3 Rebellious Aspects

*Rebellious* aspects are aspects used only to provide behavioral extensions to existing methods. Rebellious aspects change the behavior of existing methods. After the aspect is applied to a method, from the perspective of a caller of the method, the method with the advice has different assertions than the original method had. However, assertions do not change from the method's perspective.

As the category name implies, these are aspects that are determined to alter the behavior of a method to the extend where the existing pre- and post-conditions of the method are affected. Nonetheless, rebellious aspects can alter a method's pre- and post-conditions in a controlled manner:

- For all valid start states of the method's pre-condition, the new pre-condition (aspect's before pre-condition) has to also be valid.
- For all valid states according to the new post-condition (aspect's after post-condition) the original method's post-condition has to also be valid.

The above implications between the extend pre-condition (and original method pre-condition) and extended post-condition (and the original method's post-condition) ensure proper behavioral subtype between the original method and the extension to the method.

#### 3.3.1 Execution Order

A rebellious aspect is guaranteed an execution sequence imposed by the aspect that allows its advice to execute even before the method's pre-condition. This enables the redefinition of the method's pre-condition. In order to allow for the methods behavioral extension the execution order enforced by the language is (from left to right):

$$\alpha_{pre}^{bef} \rightsquigarrow \alpha \rightsquigarrow \alpha_{post}^{bef} \rightsquigarrow m_{pre} \rightsquigarrow m \rightsquigarrow m_{post} \rightsquigarrow \alpha_{pre}^{after} \rightsquigarrow \alpha \rightsquigarrow \alpha_{post}^{after}$$

In this way an extended version of the method can be provided to client programs. This kind of extension, however, raises an issue with clients as to which of the methods pre-conditions are clients supposed to follow?

The answer is either one. A rebellious aspect provides a behavioral method extension without breaking the existing method's contracts, i.e., allows for a broader set of valid start states and a narrower set of valid end states. This is reflected in the way implication between

assertions are being validated, after checking for the validity of each assertion, extra implications between pre- and post-conditions are further validated.

#### 3.3.2 Blame Assignment

Blame assignment is described in Table 4. The extra implication  $m_{pre} \rightarrow \alpha_{pre}^{bef}$  makes sure that the extension made through the aspect definition maintains the previously valid start states for the method. In case that it does not then the blame lies with the aspect developer for providing an extension that breaks existing clients of the method. The implication  $\alpha_{post}^{bef} \rightarrow m_{pre}$  verifies that after the termination of before advice and before the execution flows to the method's implementation, the program state satisfies the method's pre-condition. If before the advice post-condition implies the method's pre-condition then the method is not being wrongly used by the aspect. The implication  $m_{post} \rightarrow \alpha_{post}^{after}$  verifies that upon completion of the method body execution flows into the aspect's after advice in a correct start state for the after advice. It is therefore the responsibility of the aspect developer to make sure that all valid states reached upon return of the method are also valid start states for the aspect's after advice. Finally, the implication  $\alpha_{post}^{after} \rightarrow m_{post}$  verifies that all the valid states at after advice termination are also valid according to the original method's post-condition. This last check verifies that the set of valid end states is the same as, or a subset of, the original method's set of end states.

Assertion Validation	Blame Assignment
$m_{pre} \rightarrow \alpha_{pre}^{bef}$	Aspect
$\alpha_{pre}^{bef}$	Caller
$\alpha_{post}^{bef}$	Advice
$\alpha_{post}^{bef} \rightarrow m_{pre}$	Aspect
$m_{pre}$	Advice
$m_{post}$	Method
$m_{post} \rightarrow \alpha_{pre}^{after}$	Aspect
$\alpha_{pre}^{after}$	Advice
$\alpha_{post}^{after}$	Advice
$\alpha_{post}^{after} \rightarrow m_{post}$	Aspect

Table 4: Implications for rebellious aspect assertions and blame assignment. Order of execution goes from top (first) to bottom (last).

### 3.4 Application and Obliviousness

A DbC for AOP system is able to provide for the runtime validation of assertions on both aspects and objects allowing for the detection of errors due to erroneous aspect advice implementations, erroneous aspect composition and aspect category violations allowing for faster error detection and resolution.

The categorization into *agnostic*, *obedient*, and *rebellious* covers all behaviors that aspects can introduce to a system. Along with the incorporation of pre- and post-conditions for advice, DbC for AOP can resolve the execution order question by, e.g., introducing three new keywords to the AspectJ language that programmers can use to declare the categorizations of aspect implementations. DbC support for AspectJ would then use this classification to enforce the appropriate execution sequence according to each category. AspectJ could also extend DbC to aspects by allowing pre- and post-condition validation for advice *and* their implication on pre- and post-conditions on their attached methods. Such an implementation of DbC for AOP does not impose any restrictions on the base code, allowing the same level of obliviousness [8] as in the current implementations of AspectJ.

## 4. A CASE STUDY IN ENFORCING CONTRACTS USING ASPECTS WITH CONA

So far we tacitly ignored the question of how the enforcement of assertions on methods (and on advice) is implemented. Enforcing runtime contract checking in a program is a classical cross-cutting concern by its very nature of monitoring calls made between software entities [19, 4]. At the heart of any runtime contract checking tool lies the ability to observe and intervene between calls made from one software unit to another. The kinds of checks that need to be carried out between calls differ depending on the paradigm (e.g., functional [10] vs. OO etc.). The ability of AOP technologies to non-invasively extend a system, along with the ability to encapsulate and compose cross-cutting concerns, make AOP an ideal implementation tool for DbC.

CONA [27] is a DbC tool for both OOP and AOP. It extends Java's and AspectJ's syntax with contracts and enforces their runtime validation. CONA works by generating AspectJ aspects to enforce the runtime contract checking. CONA generates aspect definitions only for the validation of contracts on Java classes; it generates class definitions for the validation of contracts on AspectJ aspects.

In a CONA application there are always two "kinds" of aspects

1. *User-Aspects* these are aspect definitions provided by developers that affect the underlying Java program.
2. *Contract-Aspects* these are generated by CONA and are responsible for the enforcement of contracts for objects (DbC for OOP).

and two "kinds" of objects

1. *User-Objects* these are all the instances of user defined Java classes.
2. *Contract-Objects* these are all the instances of the CONA generated Java classes used for the runtime validation of contracts defined inside user aspects.

Contracts on objects are implemented by contract aspects; contracts on aspects are implemented by contract objects. The desired DbC functionality is guaranteed provided that the generated contract aspects are the only aspects in the system. However, in the presence of user aspects, and in particular, the interplay between a contract aspect and user aspects, enforcing assertions correctly is non-trivial. CONA is therefore an interesting testbed for exposing the issues of execution order and a natural client for our aspect classification.

In the remaining part of this section we further explain CONA and the language extensions to Java and AspectJ as well as CONA's mechanisms for contract enforcement. First an overview of DbC for Java is presented followed by a more detailed analysis of how CONA extends DbC for OOP to achieve DbC for AOP.

### 4.1 An AOP Solution to DbC for OOP

The AOP implementation for the provision of DbC for OOP maps each Java type to a contract aspect that is responsible for the enforcement of all contracts defined in that type. Pre- and post-conditions

and invariant expressions are generated as aspect methods. Pointcuts are generated to capture executions of a type's methods. Pointcuts are further used to distinguish which type's method is called and which type's implementation of this method is actually executed. In this way the correct type is blamed in the case of a contract

Listing 2: An aspect definition generated by CONA for enforcing-contract obligations of GRBranch.

```

1 privileged aspect GRBranch_Contract {
2   GRBranch old;
3   pointcut scope(): !within(GRBranch_Contract)
4   && !cflow(withincode(* GRBranch_Contract.*(..)));
5   pointcut GRBranch_sale(GRBranch tInst, ISBN isbn):
6     call(public * GRBranch.sale(..) && !call(public * (
7       GRBranch+ && !GRBranch).sale(..)
8     && args(isbn) && target(tInst) && scope());
9   before(GRBranch tInst, ISBN isbn):
10    GRBranch_sale(tInst, isbn){
11      boolean next = PreCondHier_sale(tInst, isbn);
12      boolean res = PreCond_sale(tInst, isbn);
13      if (!res){
14        //pre-condition violation exception
15      }
16      if (!next){
17        //pre-condition hierarchy violation exception
18      }
19    }
20  after(GRBranch tInst, ISBN isbn)returning (Book result):
21    GRBranch_sale(tInst, isbn){
22      boolean res = PostCond_sale(tInst, result, isbn);
23      if (!res){
24        //post-condition violation exception
25      }
26      boolean postHier = PostCondHier_sale(tInst, result, res, isbn)
27      ;
28      if (!postHier){
29        //post-condition hierarchy violation exception
30      }
31    }
32  public boolean PreCond_sale(GRBranch tInst, ISBN isbn){
33    return(isbn.notEqual(null))
34  }
35  public boolean PostCond_sale(GRBranch tInst, Book result,
36    ISBN isbn){
37    return(result.ISBN.equals(isbn) || isbn.getTitle().equals(
38      result.getTitle()))
39  }
40  public boolean PreCondHier_sale(GRBranch tInst, ISBN isbn){
41    boolean myPre = PreCond_sale(tInst, isbn);
42    boolean hierarchy =
43      OnlineBookstore_Contract.aspectOf().PreCondHier_sale(
44        tInst, isbn);
45    if (!hierarchy || myPre)
46      return myPre;
47    else
48      return false;
49  }
50  public boolean PostCondHier_sale(GRBranch tInst, Book result
51    , boolean last, ISBN isbn){
52    myPost = PostCond_sale(tInst, result, isbn);
53    if (!last || myPost)
54      return OnlineBookstore_Contract.aspectOf()
55        .PostCondHier_sale(tInst, result, myPost, isbn);
56    else
57      return false;
58  }
59 }

```

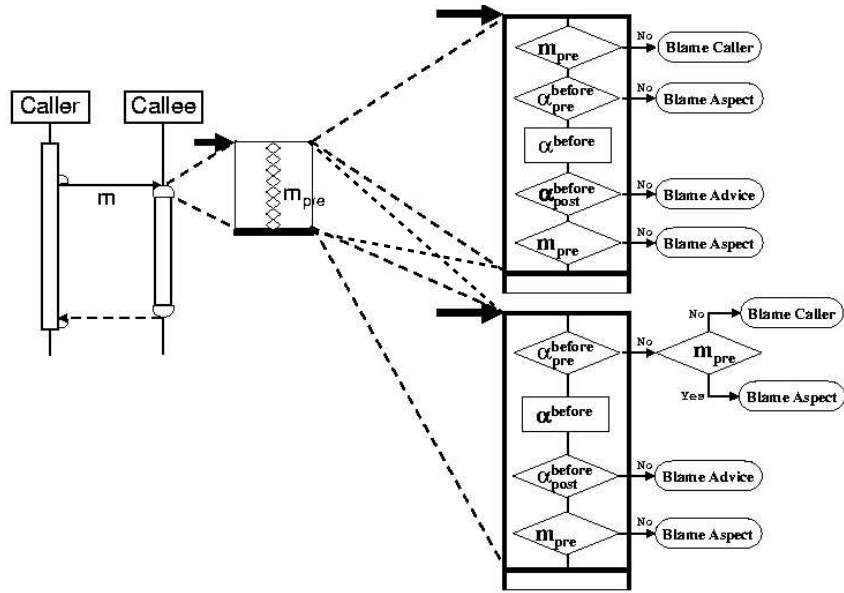

Figure 2: A flowchart diagram superimposed on a sequence diagram for a method call to  $m$  showing the order of contract evaluation for obedient aspects (top) and rebellious aspects (bottom).  $m_{pre}$  refers to  $m$ 's pre-conditions assertion and  $\alpha_{pre}^{before}$  and  $\alpha_{post}^{before}$  to the aspect's pre- and post-condition assertions respectively.

violation. Extra methods are generated which recursively traverse contracts of the current type's supertypes verifying the correctness of the type hierarchy.

Listing 2 shows an example of a contract aspect implementing a contract in AspectJ. The code has been generated by CONA [27] and it illustrates that aspects implementing contracts can follow a pattern (template): pointcut definitions capture calls to the method (lines 5–7), before advice checks method pre-conditions (lines 8–18), and after advice checks method's post-conditions (lines 19–29). Invariant assertions are checked both before and after a call to the object's public methods. Auxiliary methods are generated inside aspects to deal with hierarchy checking (lines 36–51) [9]. The recipe for CONA's aspect generation is explained elsewhere [28].

Blame assignment for OOP [9] is summarized in Table 5. The last two rows display the type hierarchy check performed in order to verify proper behavioral subtyping. Due to the lack of aspectual polymorphism [5, 6] in AspectJ, the traversal of contracts in CONA deploys AspectJ's reflective features in order to acquire aspect instances at runtime.

The AOP implementation of DbC for OOP works well as long as the generated aspects are the only aspects in the system.

Contract Value	Blame Assignment
$\neg m_{pre}$	Caller
$\forall \tau, \tau' (\tau' \prec: \tau \wedge \tau:: m \wedge \tau':: m) \rightarrow \neg(\tau:: m_{pre} \rightarrow \tau':: m_{pre})$	$\tau'$
$\neg m_{post}$	Callee
$\forall \tau, \tau' (\tau' \prec: \tau \wedge \tau:: m \wedge \tau':: m) \rightarrow \neg(\tau':: m_{post} \rightarrow \tau:: m_{post})$	$\tau'$

Table 5: Blame assignment rules for OOP.  $\tau' \prec: \tau$  defines that  $\tau'$  is a direct subtype of  $\tau$ .  $\tau:: m_{pre}$  denotes the method  $m$  with pre-conditions  $pre$  is defined in type  $\tau$ .

## 4.2 An OOP Solution to DbC for AOP

A DbC for AOP solution has to be able to enforce the execution sequence required by each aspect category as well as manage pre- and post-conditions found in user aspect definitions.

Figure 2 uses a flowchart diagram superimposed on an interaction diagram showing when obedient (top) and rebellious (bottom) aspects intervene during  $m$ 's execution, and what is the order of contract evaluation for these two aspect categories.<sup>3</sup> Aspect category definitions denote a specific order of contract evaluation as well as implications between assertions in contract aspects and contract objects. All diamond shaped decision points are generated by CONA. Decision points denoted as diamonds in Figure 2 and labeled with an  $\alpha$  pattern are captured as Java classes (contract objects). Diamond shaped decision points labeled with an  $m$  pattern are captured as AspectJ aspects (contract aspects).

To support pre- and post-conditions for before and after advice we assume the AspectJ language was extended with the keywords `agnostic`, `obedient` (e.g., Listing 3, line 1), and `rebellious`, and, furthermore, that advice definitions can be annotated with pre- and post-conditions that apply to the corresponding advice body (Listing 3 lines 7– 8). Pre- and post-conditions are comprised of side effect free boolean expressions.

The extension of CONA for adding contracts to advice takes as input aspect definitions with pre- and post-conditions. Through a preprocessing stage, new aspects are generated to verify contracts on object instances *and* auxiliary class definitions to handle pre- and post-conditions on user defined advice.

First we present a sample program definition of advice with pre- and post-conditions along with the generated output. Listing 3 shows the obedient `ShippingCost` aspect presented earlier for the

<sup>3</sup>Agnostic aspects are similar to obedient aspects with some additional contract checks interleaved during execution.

Listing 3: An example of using pre- and post-conditions in the ShippingCost aspect

```

1 obedient aspect ShippingCost{
2   pointcut HDSales(ISBN isbn):
3   call(* OnlineBookstore.sales(..) && args(isbn);
4
5   after(ISBN isbn) returning (Book item):
6     HDSales(isbn){
7       @pre{item.getBookType() = HD}
8       @post{item.getShippingCost() = Calc.ShippingCost(item.
9         ISBN) * 1.1}
10      item.setShippingCost(item.getShippingCost() * 1.1);
11      item.calculateTotalCost();
12    }
}

```

Listing 4: Sample output for ShippingCost aspect showing the wrapping of advice to check pre- and post-conditions

```

1 aspect Contract_ShippingCost {
2   pointcut HDSales(ISBN isbn):
3   call(* OnlineBookstore.sales(..) && args(isbn);
4
5   after(ISBN isbn) returning (Book item):
6     HDSales(isbn){
7       boolean implication1 = (new
8         Contract_ShippingCost_After_PreCond()).HDSales(
9         thisJoinPoint,this,thisJoinPoint.getTarget(),isbn,
10        item);
11      if (implication1){
12        if(item.getBookType()==HD){
13          item.setShippingCost(item.getShippingCost() * 1.1);
14          item.calculateTotalCost();
15          if (item.getShippingCost()==Calc.ShippingCost(item.
16            ISBN) * 1.1){
17            (new Contract_ShippingCost_After_PostCond).
18              HDSales(this,thisJoinPoint.getTarget(),isbn,
19                item);
20          }else{
21            new Error(this,"before".jp);
22          }
23        }else{
24          new CompositionError(jp.getTarget().getClass().
25            getName(),this,thisJoinPoint);
26        }
27      }else{
28        new ObedientViolation(jp.getTarget().getClass().
29          getName(),this,thisJoinPoint);
30      }
31    }
}

```

online bookstore example written in CONA. Listing 4 shows the same aspect as Listing 3 after being processed by CONA. The auxiliary class definitions (Listings 5 and 6) enforce the implications between contract objects and contract aspects.

Pre- and post-conditions inside advice must be side effect free Java boolean expressions. These expressions can refer to values that relate to the state of the aspect, and also to the state of the receiver and the caller of method invocations. All information concerning a join point (e.g. target, args, source, etc.) can be referred to from inside an aspect's pre- and post-conditions definitions.

The programmer must specify the aspect's category and the acceptable states in which advice may start/finish. Failing to meet the

Listing 5: Pre-condition wrapper for aspect after advice

```

1 import org.aspectj.lang.*;
2
3 class Contract_ShippingCost_After_PostCond {
4
5   public boolean HDSales(JoinPoint jp, Contract_ShippingCost
6     uAspect, Object target, ISBN isbn, Book item){
7     String targetType = target.getClass().getName();
8     // Holds references to contract (aspects)
9     AspectMethInvoker alnv = AspectMethInvoker.getInst();
10
11    // call appropriate contracts via reflection
12    boolean m_post = aInv.invokePost(targetType, jp.getSignature
13      (), jp.getArgs(), item);
14    boolean res = (item.getShippingCost() == Calc.ShippingCost(
15      item.ISBN) * 1.1);
16    if (!res || m_post){
17      return res;
18    }
19    else {
20      new CompositionError(targetType,uAspect,jp);
21      return false;
22    }
23  }
}

```

Listing 6: Post-condition wrapper for aspect after advice

```

1 import org.aspectj.lang.*;
2
3 class Contract_ShippingCost_After_PostCond {
4
5   public boolean HDSales(JoinPoint jp, Contract_ShippingCost
6     uAspect, Object target, ISBN isbn, Book item){
7     String targetType = target.getClass().getName();
8     // Holds references to contract (aspects)
9     AspectMethInvoker alnv = AspectMethInvoker.getInst();
10
11    // call appropriate contracts via reflection
12    boolean m_post = aInv.invokePost(targetType, jp.getSignature
13      (), jp.getArgs(), item);
14    boolean res = (item.getShippingCost() == Calc.ShippingCost(
15      item.ISBN) * 1.1);
16    if (!res || m_post){
17      return res;
18    }
19    else {
20      new CompositionError(targetType,uAspect,jp);
21      return false;
22    }
23  }
}

```

pre-condition of a block of advice implies that the attachment of the specific aspect to the base program  $P$  is not correct (Listing 4 line 18) and the aspect gets blamed. Similarly, if the post-condition of a piece of advice fails, this implies that the code inside the advice did not meet up to its obligations (Listing 4, line 15) and the advice code gets the blame.

Once pre- and post-conditions have been satisfied, the way by which pre- and post-conditions of advice interplay with method pre- and post-conditions of methods that they advice are checked for correctness based on the aspects defined category.



In the case of an obedient aspect (i.e., `ShippingCost`), before the execution of the after advice block the implication between the method's post-condition and the after advice pre-condition (Listing 4, line 7) is checked by passing control to an auxiliary class (Listing 5). Failing to satisfy this implication throws an `ObedientViolation` (Listing 4, line 21) exception pointing out the erroneous implementation of the aspect's before advice. The advice pre-condition and post-condition is then checked, blaming the aspect's composition and the after advice implementation respectively (Listing 4, lines 18 and 15)

## 5. DISCUSSION AND RELATED WORK

We have extended DbC for AOP to handle the interaction between pre- and post- conditions of methods and advice. Our goal was primarily to demonstrate the feasibility a novel approach for supporting DbC for AOP without compromising obliviousness. We have also presented a prototyped tool for enforcing DbC by generating aspects. This work paves the road to extending DbC for AOP but also leaves for future work a few issues that are need to be worked out for a complete practical support of DbC for AOP.

**Invariants and Object State.** DbC makes the obligation–benefit contract between software consumers and providers explicit. Each instance method defines the valid states in which its execution can start (*precondition*), and the states in which it may terminate (*post-condition*). A more general assertion (*invariant*), which is maintained before as well as after any externally observable state of an object, ensures that the object maintains an acceptable state throughout the program's execution. Object and aspect invariants can be checked by public methods as part of the pre- and post-conditions using the same execution order we have established. However, to handle invariants, DbC for AOP needs not only control the interaction between aspects and object behavior, but also between aspects and object state. It is also not enough to monitor only call and execution join points. Since advice can change the state of an object, the interaction between advice and objects' state need to be checked to enforce invariants. Additional checks are needed for checking the invariant of super-classes and outer classes. Invariants for aspects are particularly useful as an inductive hypothesis: What ever is assumed should be inductively provable.

**Other Kinds of Advice.** We have focused on the interaction between methods and before and after advice. An around advice replaces the method entirely and may or may not contain a `proceed()` call in its body. Such a narrowing or replacement interaction [25] should be handled similar to how overriding methods handle a call to `super`. One way of interpreting the aspect annotation for around advice is to require that an around advice of the form `f(); proceed()` would behave like a before advice would, and an around advice of the form `proceed(); f()` would behave like an after advice.

**Introductions and Pointcut Descriptors.** We have concerned ourselves with the pointcut and advice mechanism in AspectJ. AspectJ also support a static OC mechanism (e.g., introductions). This is yet another form for a possible interaction between an aspect and a class which we do not handle. Another subtle issue is the interaction between aspects and pointcuts. In our support of DbC for AOP we have thus far assumed that pointcuts have no side effects. This, however, is not generally true, not even for AspectJ. One might consider augmenting pointcut descriptors with pre- and post-conditions of their own.

**Aspect Composition Validation Tool.** Klaeren et al. [13] present the *Aspect Composition Validation Tool* for checking pre- and post-conditions for aspect compositions according to configurations of the system's components. The tool is developed using an older version of AspectJ (0.4beta7) which is drastically different than version 1.0.6. Further more, a set of configuration rules is added through AspectJ's introductions and composition is validated according to these rules. Correctness is defined to be a valid aspect configuration that will allow a receiver to perform its task as specified by the overall system specification. Unfortunately, checking that the behavior of attached aspects and the base system is well defined is not verified. As long as the composition of aspects is within the set of valid compositions, the system is correct. An aspect can therefore break a methods pre- or post-condition as long as the configuration at hand allows it. There is no clear distinction between a type's obligations in their system, since the same call to an instance of the same type can behave differently depending on its aspect configuration.

**JML.** Clifton and Leavens [2] use behavioral specifications for aspects as a means to assist in modular reasoning for aspect-oriented programs. Aspects are categorized as either observers that do not alter the behavioral specification of their attached methods, or as assistants that can alter behavior. Their categorization was a result after inspecting available AspectJ code and from discussions within the aspect community.

Assertions on aspects as well as objects are expressed in the Java Modeling Language (JML) [16]. The AspectJ syntax is extended with three main features:

1. JML can be used inside aspect definitions, defining the aspect's behavioral specification
2. Keywords `observer` and `assistant` can be used to annotate aspect definitions with their expected intend in the system.
3. The statement `accept (TypePattern)` has to be used inside modules, making explicit the modules intent to allow assistance from *TypePattern*.

The specification of a method along with its assistant is created as a graph by following the possible execution paths, logically and-ing assertions and binding parameter variables and model variables to values.

Although our goals are different than those of Clifton and Leavens the proposals share some ideas. Our notion of aspect categorization comes from an analysis of how aspects can affect a program execution and not through an analysis of existing usage of aspect oriented programming. In doing so we aim at providing a categorization that covers any possible usage of aspects rather than the common usage of aspects. Further more, our proposal brings these categorizations into the programming language and enforces an execution order disallowing aspect behavior outside the bounds of its defined category. Enforcing an execution sequence helps in defining the semantics of assertion validation along with blame assignment without having to resort to long and complicated path specifications based on control flow paths. Finally, in our proposal modules are not affected in any way and remain oblivious to the addition of aspects. Obliviousness is decreased in Clifton et al. [2] with the incorporation of the `accept` expression in the language.

**Pipa.** Pipa [31] defines a Behavioral Interface Specification Language (BISL) tailored for AspectJ along the ideas of Clifton et al. [2]. Pipa statements extend the Java Modeling Language (JML) to accommodate pre- and post-conditions and invariants for advice. Specifications in Pipa, along with aspect definitions, are translated to JML and Java code, respectively. Pipa differs from the proposal of Clifton and Leaves. Assertions are allowed on aspect introductions and the `accept` expression is not provided by Pipa. Furthermore, the AspectJ language is not extended to accommodate for the definition of `observer` and `assistant` aspect definitions. Behavioral specifications inside aspects are translated into JML specifications following the specification generation of execution paths as defined in [2]. Pipa does not provide, nor enforce, aspect categories. By concentrating on AspectJ's intermediate Java representation of aspect programs, Pipa becomes part of the AspectJ compiler making extensions difficult and blame assignment more complex.

**Classification system.** Rinard et al. [25] present a classification that is also derived from the interaction of advice and methods. Their focus is on automated analysis, while our work focuses on enforcing contracts based on annotations. The interaction between agnostic aspects and methods can be classified as *augmentation* in their classification. The obedient and rebellious aspects we have identified refine their *combination* class of interactions. The *narrowing* and *replacement* interactions can help in extending our work to also handle around advice with or without proceed. Their additional classification of scopes and field access, can also help in extending our DbC tool to handle set-field and get-field advice. Automated classification to help suggest or verify aspect categories annotation is a direction for future work.

## 6. CONCLUSION

The paper discusses the intricate issues related to DbC for AOP. The dynamic nature of aspects along with the base system's obliviousness render existing DbC methodologies inadequate for dealing with aspect-oriented programs. This inadequacy unavoidably leads to erroneous error reporting and blame assignment. An extension to DbC to address aspect-oriented programming requires more than simple assertion validation at each program execution point where aspect advice gets to execute. A DbC mechanism for AOP has to address both the execution order of contracts (on classes and aspects) as well as the implications (if any) that must be validated between contracts on aspects and contracts in classes. Based on these decisions of execution order and contract implications, blame assignment can be defined.

We provide an analysis of the possible execution order between contracts and view the addition of advice as a behavioral extension to the existing program. Our analysis leads us to a categorization of aspects into agnostic, obedient and rebellious. Each such categorization enforces an execution order between contracts as well as the necessary implications that verify at runtime that the extended (through aspects) system remains a behavioral subtype of the unextended original system. Error reporting and blame assignment is extended to deal with contracted aspect oriented systems. Our ideas have been integrated in CONA, an aspect-based DbC tool for AOP which uses aspects to implement contracts and their runtime validation. CONA serves both as a language extension to Java and AspectJ, but also as a case study for our own work.

Through the development and usage of CONA we hope to improve the ability to reasoning about the interactions of aspects with other

program entities including aspects themselves. We believe that the incorporation of pre- and post-conditions on `before` and `after` advice is a step forward towards reasoning about aspects and their behavior.

## 7. REFERENCES

- [1] AOSD 2003. *Proceedings of the 2<sup>nd</sup> International Conference on Aspect-Oriented Software Development*, Boston, Massachusetts, Mar. 17-21 2003. ACM Press.
- [2] C. Clifton and G. T. Leavens. Observers and assistants: A proposal for modular aspect-oriented reasoning. Technical Report 02-04a, Iowa State University, Department of Computer Science, Apr. 2002.
- [3] A. Colyer. Aspectj. In Filman et al. [7], pages 123–143.
- [4] C. A. Constantinides and T. Skotiniotis. Reasoning about the classification of crosscutting concerns in object-oriented systems. In *Second International Workshop on Aspect-Oriented Software Development*. German Informatics Society, February 21-22 2002.
- [5] E. Ernst and D. H. Lorenz. Aspectual polymorphism. Technical Report NU-CCS-01-09, College of Computer Science, Northeastern University, Boston, MA 02115, Sept. 2001.
- [6] E. Ernst and D. H. Lorenz. Aspects and polymorphism in AspectJ. In AOSD 2003 [1], pages 150–157. <http://www.ccs.neu.edu/home/lorenz/papers/aosd2003polyspect/>
- [7] R. E. Filman, T. Elrad, S. Clarke, and M. Akşit, editors. *Aspect-Oriented Software Development*. Addison-Wesley, Boston, 2005.
- [8] R. E. Filman and D. P. Friedman. Aspect-oriented programming is quantification and obliviousness. In Filman et al. [7], pages 21–35.
- [9] R. B. Findler and M. Felleisen. Contract soundness for object-oriented languages. In *Proceedings of the 16<sup>th</sup> Annual Conference on Object-Oriented Programming Systems, Languages, and Applications*, pages 1–15. Tampa Bay, Florida, Oct. 14-18 2001. OOPSLA'01, ACM SIGPLAN Notices 36(11) Nov. 2001.
- [10] R. B. Findler and M. Felleisen. Contracts for higher-order functions. In *International Conference on Functional Programming (ICFP'02)*, pages 48–59, October 2002.
- [11] M. Kersten and G. C. Murphy. Atlas: A case study in building a web-based learning environment using aspect-oriented programming. In *Proceedings of the 14<sup>th</sup> Annual Conference on Object-Oriented Programming Systems, Languages, and Applications*, pages 340–352, Vancouver, BC, Canada, Oct. 18-22 1999. OOPSLA'99, ACM SIGPLAN Notices 34(10) Oct. 1999.
- [12] G. Kiczales, E. Hilsdale, J. Hugunin, M. Kersten, J. Palm, and W. G. Griswold. An overview of AspectJ. In J. L. Knudsen, editor, *Proceedings of the 15<sup>th</sup> European Conference on Object-Oriented Programming*, number 2072 in Lecture Notes in Computer Science, pages 327–353, Budapest, Hungary, June 18-22 2001. ECOOP 2001, Springer Verlag.

- [13] H. Klaeren, E. Pulvermüller, A. Rashid, and A. Speck. Aspect composition applying the design by contract principle. In *Proceedings of the GCSE 2000, Second International Symposium on Generative and Component-Based Software Engineering, 2000*, Oct 2000.
- [14] M. Kölling and J. Rosenberg. *Blue: Language Specification*, 1997.
- [15] S. Krishnamurthi, K. Fisler, and M. Greenberg. Verifying aspect advice modularly. In Taylor and Dwyer [30], pages 137–146.
- [16] G. T. Leavens, C. Ruby, K. Rustan, M. Leino, E. Poll, and B. Jacobs. Jml: notations and tools supporting detailed design in java (poster session). In *Proceedings of the 15<sup>th</sup> Annual Conference on Object-Oriented Programming Systems, Languages, and Applications*, pages 105–106, Minneapolis, Minnesota, Oct. 15-19 2000. OOPSLA'00, ACM SIGPLAN Notices. Also Department of Computer Science, Iowa State University, TR 00-15, August 2000.
- [17] K. Lieberherr, D. H. Lorenz, and P. Wu. A case for statically executable advice: Checking the Law of Demeter with AspectJ. In AOSD 2003 [1], pages 40–49. <http://www.ccs.neu.edu/home/lorenz/papers/aosd2003lod/>
- [18] B. Liskov and J. Wing. A behavioral notion of subtyping. *ACM Trans. Prog. Lang. Syst.*, 16(6):1811–1841, Nov. 1994.
- [19] C. Lopes, M. Lippert, and E. Hilsdale. Design by contract with aspect-oriented programming, 2002. U.S. Patent No. 06,442,750. Issued August 27,2002.
- [20] C. V. Lopes and G. Kiczales. Recent developments in AspectJ. In S. Demeyer and J. Bosch, editors, *Object-Oriented Technology. ECOOP'98 Workshop Reader*, number 1543 in Lecture Notes in Computer Science, pages 398–401. Workshop Proceedings, Brussels, Belgium, Springer Verlag, July 20-24 1998.
- [21] D. H. Lorenz and T. Skotiniotis. Contracts and aspects. Technical Report NU-CCIS-03-13, College of Computer and Information Science, Northeastern University, Boston, MA 02115, Dec. 2003. <http://www.ccs.neu.edu/home/lorenz/papers/reports/NU-CCIS-03-13.html>
- [22] B. Meyer. Applying design by contract. *Computer*, 25(10):40–51, Oct. 1992.
- [23] B. Meyer.  *Eiffel the Language*. Object-Oriented Series. Prentice-Hall, 1992.
- [24] S. M. Omohundro. The Sather 1.0 specification. Technical Report TR-94-062, International Computer Science Institute, Berkeley, 1994.
- [25] M. Rinard, A. Salcianu, and S. Bugrara. A classification system and analysis for aspect-oriented programs. In Taylor and Dwyer [30], pages 147–158.
- [26] T. Skotiniotis. Cona Home Page, 2004. <http://www.ccs.neu.edu/home/skotthe/cona/>.
- [27] T. Skotiniotis and D. H. Lorenz. Cona: aspects for contracts and contracts for aspects. In J. M. Vlissides and D. C. Schmidt, editors, *OOPSLA Companion*, pages 196–197, Vancouver, BC, Canada, Oct. 24-28 2004. ACM. <http://doi.acm.org/10.1145/1028664.1028747>
- [28] T. Skotiniotis and D. H. Lorenz. Conaj: Generating contracts as aspects. Technical Report NU-CCIS-04-03, College of Computer and Information Science, Northeastern University, Boston, MA 02115, Mar. 2004.
- [29] T. Skotiniotis and D. H. Lorenz. From contracts to aspects and back. Technical Report NU-CCIS-04-05, College of Computer and Information Science, Northeastern University, Boston, MA 02115, Mar. 2004.
- [30] R. N. Taylor and M. B. Dwyer, editors. *Proceedings of the 12<sup>th</sup> ACM SIGSOFT International Symposium on Foundations of Software Engineering*, Newport Beach, CA, USA, 2004. ACM Press.
- [31] J. Zhao and M. Rinard. Pipa: Behavioral Interface Specification Language for AspectJ. In *Proceedings of Fundamental Approaches to Software Engineering (FASE'2003)*, pages 150–165, 2003.